

nonlinearcircuits

IS CARP LUST WRONG build & BOM

This module is loosely based on the Karplus Strong algorithm. You may get it to make some plucked string sounds or you might just get lost in a rubbery glitch mess. Most likely, Messrs. Karplus and Strong would drag me out into the carpark for a kicking if they heard this module.....or even saw the name.



This is not a press-a-button-and-sound-cool module, it takes tweaking.

To get started, it needs a trigger or gate on the EG Trig input.

Make sure Noise Level is turned up, Noise Colour goes from white to pink noise. This pot is disabled if an external noise/sound seed is used.

The Attack and Decay pots need to be set, Attack can stay at 0 for more of an impact, Decay should be above zero to get some sound into the loop. In a proper K-S system, the envelope is very short so just a portion of the sound wave is obtained. In this module the envelope can be held open for a few seconds. The EG can be easily modded to keep the envelope very short but it is more fun to have the option for longer envelopes.

Next turn up the Feedback and Rate pots, probably somewhere around the area shown in the pic above. After this, adjust Cutoff until you can hear something. Once you have a sound you can start sculpting it and adding CV to get things moving around.

Both the Q and Feedback pots will make the module self-oscillate when turned up high. Getting the sounds you want often comes down to a delicate balancing act between these two pots.

The VCO / BBD clock should range from approx. 100Hz to 300kHz. This is above and below the normal operating range of the BBD chips. It is fun to use the lower frequencies to get some lovely DelayNoMore type effects,

tho the Cutoff pot will have to be tweaked to reduce the clock noise.
The VCO is approx. 1V/oct but has no temperature compensation.

The module can be fitted with a v3207 1024 stage BBD OR a v3205 4096 stage BBD. Only install one or the other, not both. Initially I liked both versions, but feel the v3205 sounds better with slow clocking glitchy stuff, so prob that will be the one I keep in the rack.

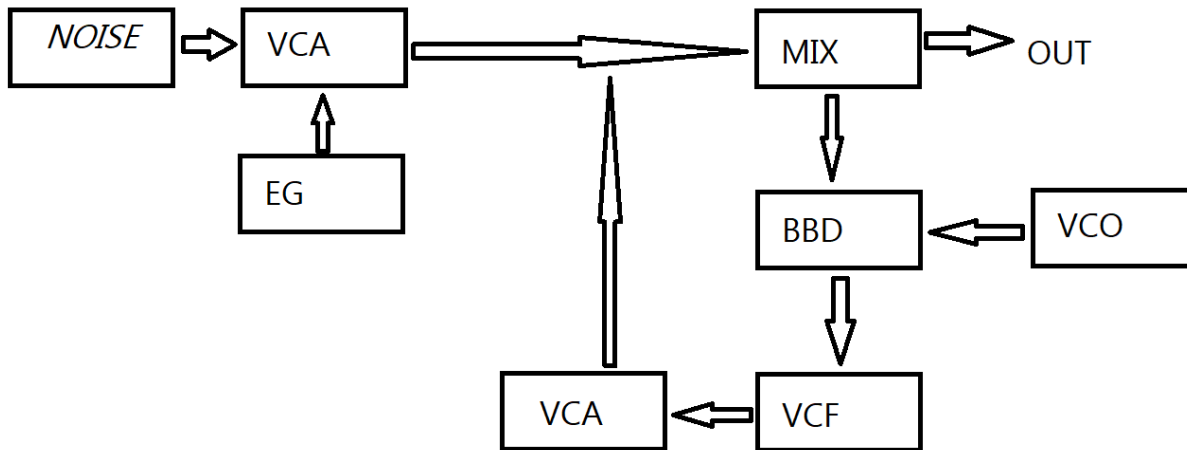

BOM – The Tayda & Mouser part numbers are given as examples

Get spares – you might drop something or my counting might be a bit off!

VALUE	QUANTITY	DETAILS
10p	2	0805
47p	1	0805
330p	2	0805
1n	1	0805
10n	2	0805
22n	1	0805
100n	8	0805
1u	3	0805
10u	4	0805 25V or higher voltage rating
22R	2	0805
220R	2	0805
470R	4	0805
1k	7	0805
1k8	2	0805
3k3	1	0805
4k7	3	0805
10k	13	0805
12k	3	0805
15k	3	0805
30k	3	0805
33k	2	0805
39k	1	0805
47k	4	0805
56k	1	0805
100k	22	0805
150k	4	0805
300k	1	0805
1M	3	0805
4M7	1	0805
LED	1	3mm
TL072 or TL082	6	soic Tayda: A-1139
TL074 or TL084	1	tayda A-1137 or A-1140
555 or 7555	1	soic tayda A-074
BC857	5	tayda A-1345
BC847	4	Tayda A-1339
J309 FET	1	sot23-3 Mouser Part No: 863-MMBFJ309LT1G
LL4148	5	sod-80 Tayda: A-1213
LM13700M or V13700M	3	Mouser Part No 926-LM13700MX/NOPB or V13700M at synthcube (cheaper)
40106	1	soic Mouser Part No: 771-HEF40106BTD-T or similar
LM78L05	1	soic Tayda A-629
5V1 zener	4	Tayda A-6014 (5V6 but ok)
Eurorack 10 pin power connector	1	Tayda: A-198 cut to size
S1JL, Schottky, power rectifier	2	SMD SEE NOTES #1. dot on PCB indicates CATHODE (stripe on component).
3.5MM mono SOCKET	7	Tayda: A-2563
100k pot	11	Tayda: A-4729 or similar
10 Pin 2.54mm Single Row Female Pin Header	2	Tayda A-1306
5 Pin 2.54mm Single Row Female Pin Header	1	optional – for stability only (I don't bother) Tayda: A-1421
40 Pin 2.54mm Single Row Pin Header Strip	1	Tayda A-5773 cut to two 10 pin sections and one 5 pin section (if desired)
V3207 or V3205 BBD	1	DIP try Synthcube
8 and/or 14 pin IC socket	1	Tayda: A-001 or A-004

Additional notes:

1. , Schottky (best option) or standard power rectifier diode 50-600V 1A or more, or use a resettable fuse or just a 10R (worst option). Examples: BAT54GWX, PMEG2005EGWX, AEC-Q101, 20V, SOD-123, PMEG2005EH DIODE, SCHOTTKY, 0.5A, 20V, 1N400x or S1JL or similar. More examples (Mouser numbers) - 621-B1100-F, 511-STPST1H100AF, 511-STPST1H100ZF, 511-STPST1H100AFY, 771-PMEG10010ELR-QX

2. The chips, resistors, caps are cheapest from Tayda. Synthcube is also a good source of many parts. Schottky diodes, CMOS & 1uF, 10uF 25V 0805 caps from Mouser/E14/Farnell/etc.

3. Join the Nonlinearcircuits Builders Guild on FB: <https://www.facebook.com/groups/174583056349286/> and ask questions there if you have any. If you prefer not to FB then email is fine.

4. Sorry the print on the purple PCBs is not always easy to read. It was fine on the green proto-type boards but a bit blurred on purple. Refer to pics on the following pages to check component values.

5. To reduce the range of the EG, change the 10uF* next to the Attack pot (below a diode) to a smaller value. I originally started with 470pF but decided longer envelopes were more fun.

6. If the noise level is too low, increase the 4M7 to 6M8 or even 10M.

7. Bandpass out can be quite low in normal use but gets to 10Vp-p when the module is self-oscillating. If you want it hotter, change the 100k, next to the opamp where the BP out label is printed to a higher value, say 150k or 220k. The output has zeners to keep it between +/-5V, so don't worry if it is too hot.

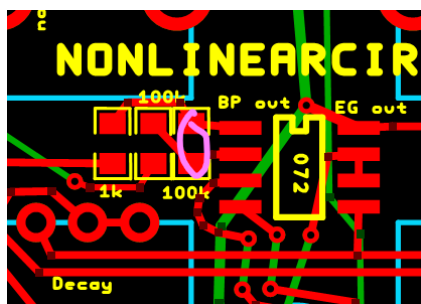

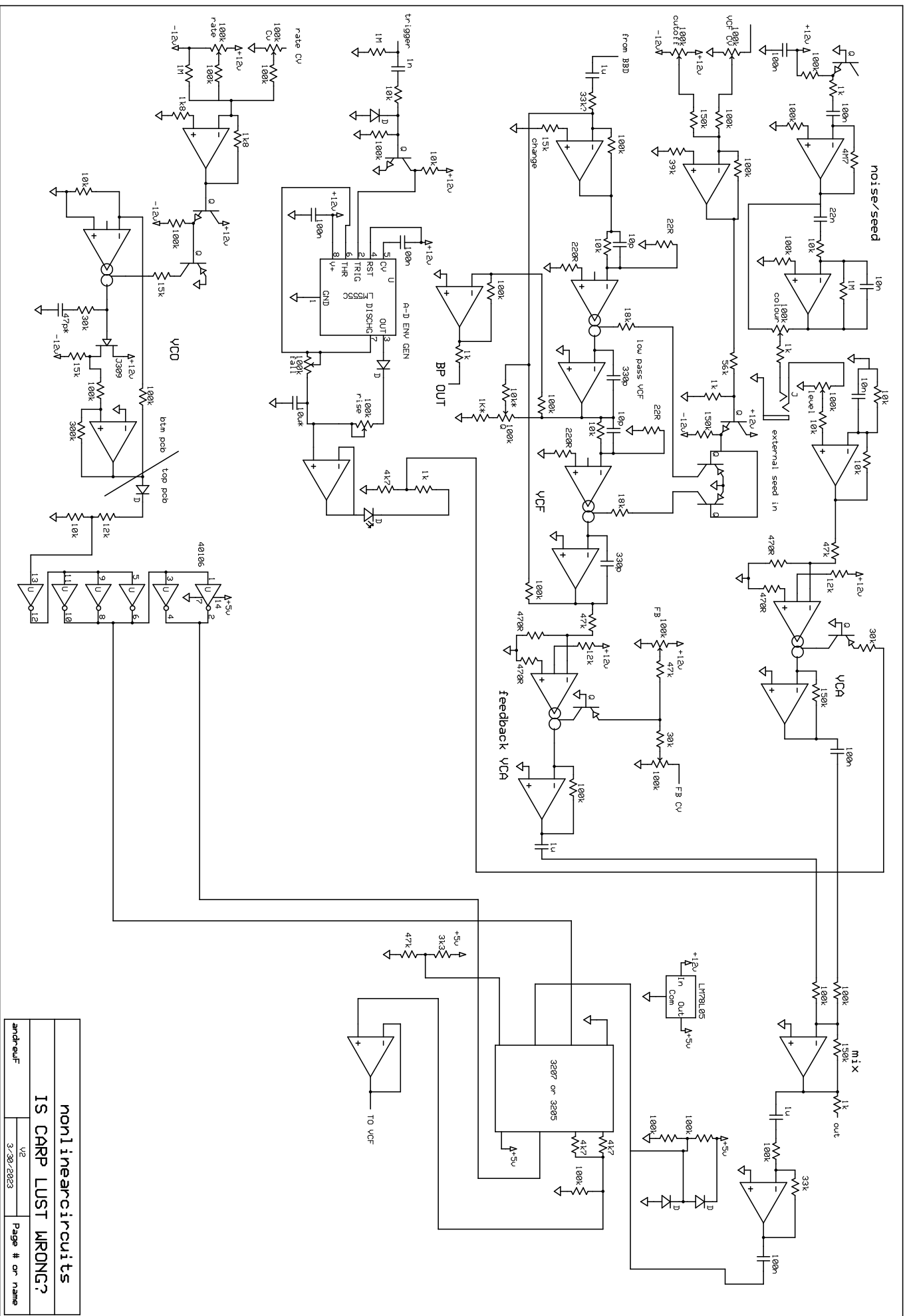

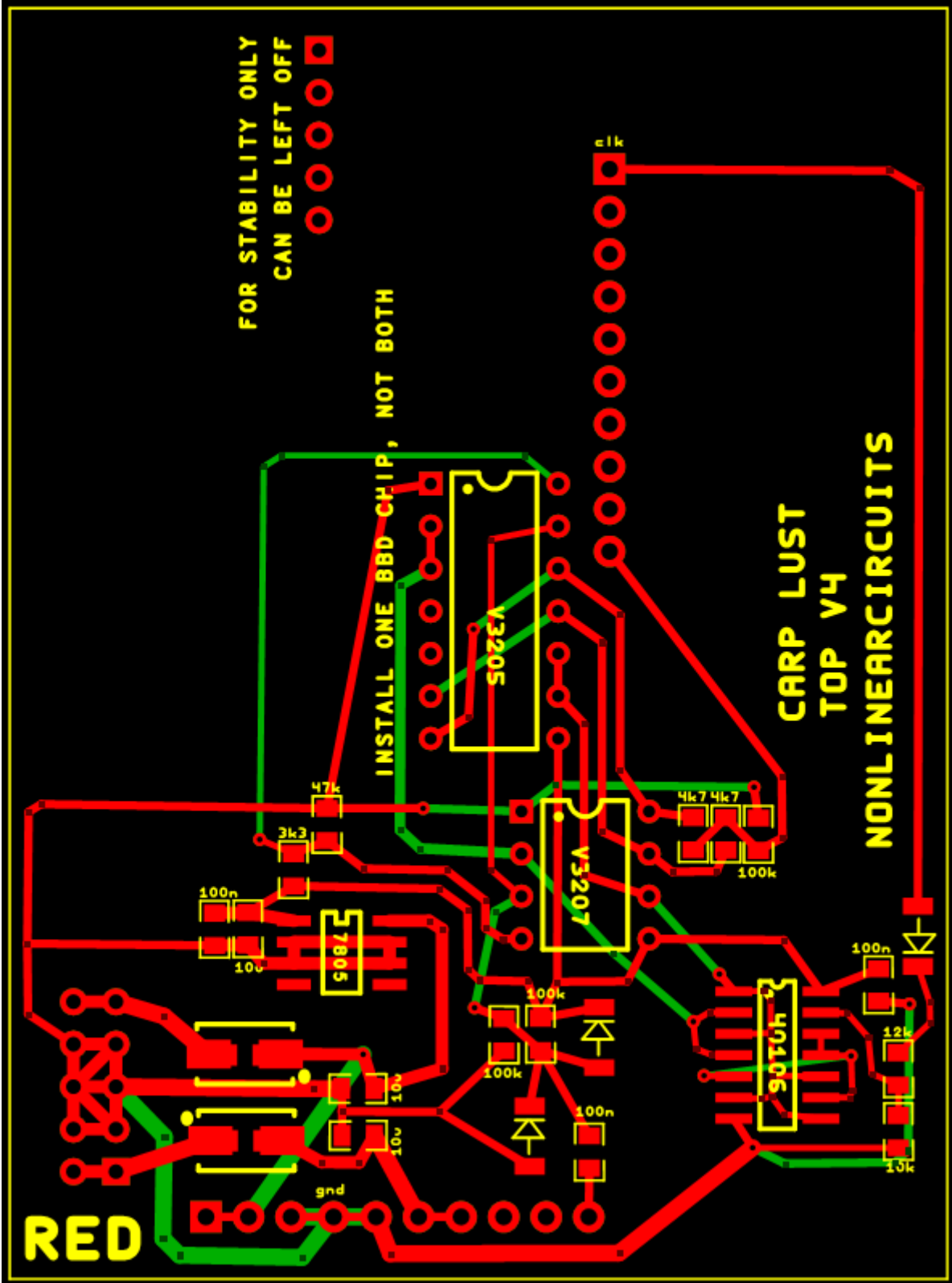

FOR STABILITY ONLY
CAN BE LEFT OFF



INSTALL ONE BBD CHIP, NOT BOTH

**CARP LUST
TOP V4
NONLINEAR CIRCUITS**

RED

1k

gnd

V3205

V3207

7805

4910C

4910E

100n

10u

3k3

47k

4k7

4k7

100k

100k

100k

100n

100n

100n

12k

15k

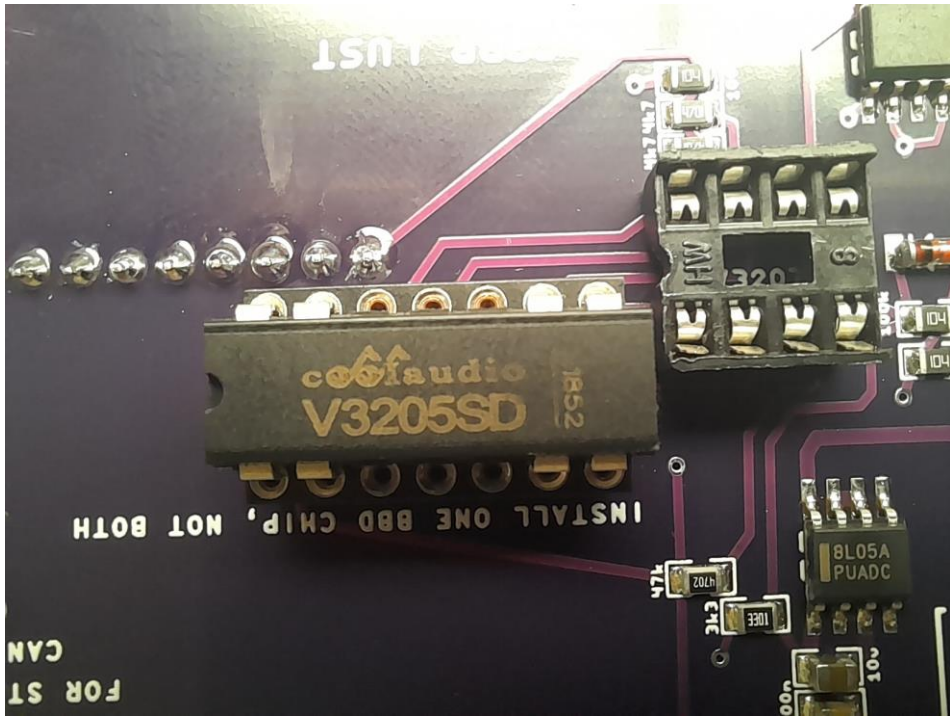

IS CARP LUST WRONG?

VCF CV	CUTOFF	
	RATE CV	RATE
	F/BK CV	FEEDBACK
EXT NOISE	NOISE LVL	COLOUR
EG TRIG	ATTACK	DECAY
BP OUT		
MAIN OUT		

